

garage as proposed

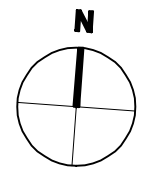

garage as existing

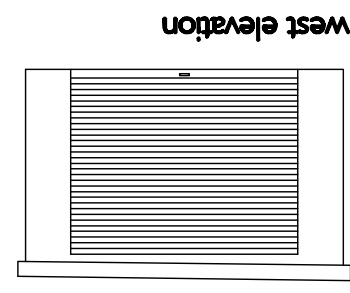
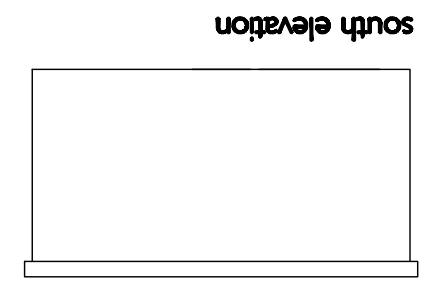
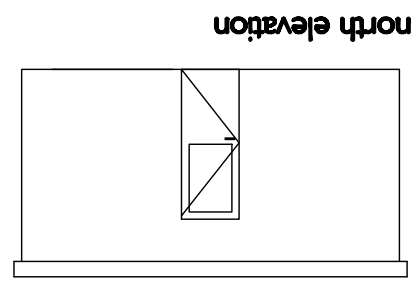
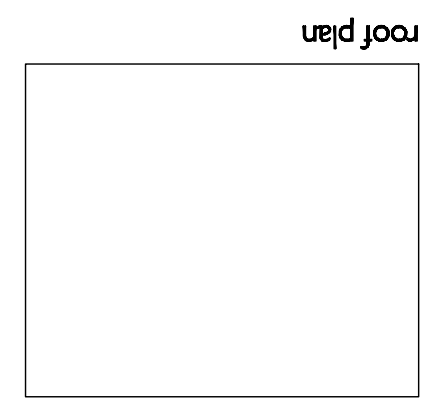
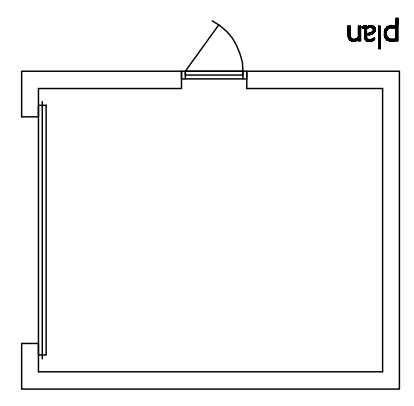
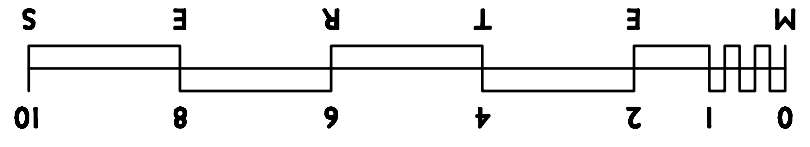
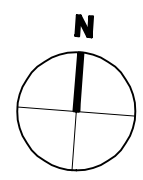
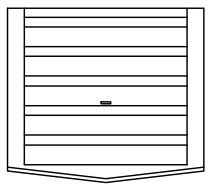
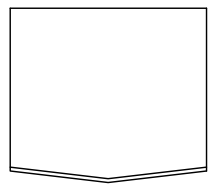
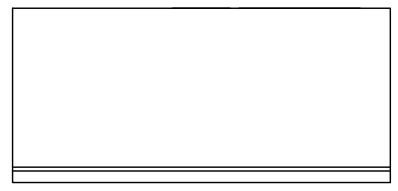
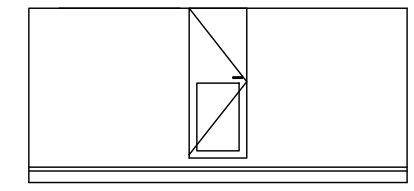
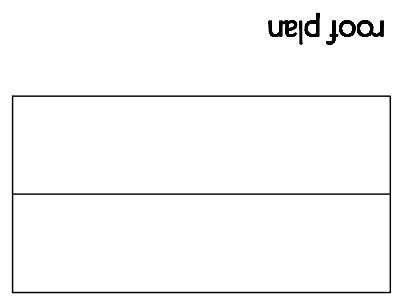
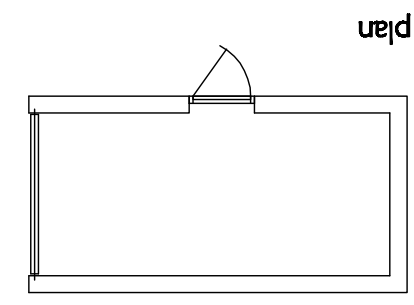

Rev	Planning issue	BW	RM	13-09-2017
Rev	Revision details			
Client Mr Meade				
Project Proposed New Garage 68 Pall Mall Leigh-on-Sea SS9 1RG				
Drawing Plans and Elevations Proposed and Existing				
Drawn	DESIGN	FOR COMMENT		
Designed	PLANNING CONTROL	X FOR INFORMATION		
File ref	183048484	TENDER	FOR REVISION	
Tal No.	01273 734064	CONSTRUCTION	FOR RECORD	
Drawing No 383/02 Scale @ A3 Rev 1:100				

DO NOT SCALE FROM THIS DRAWING. All dimensions to be verified on site.  
 This drawing has been produced for the specific client and project identified below and is not intended for use by any other person or for any other purpose.  
 © Sustainable Evolution Ltd